

Maharashtra State Board
Class X
Science and Technology Paper – II
Sample Paper 1

Time: 2 hrs

Max. Marks: 40

Note:

- (i) All questions are compulsory.
- (ii) All questions carry equal marks.
- (iii) Draw neat and labelled diagrams wherever necessary.

1.

(A) Solve the following questions:

[5]

(1) Correct and complete the given chart.

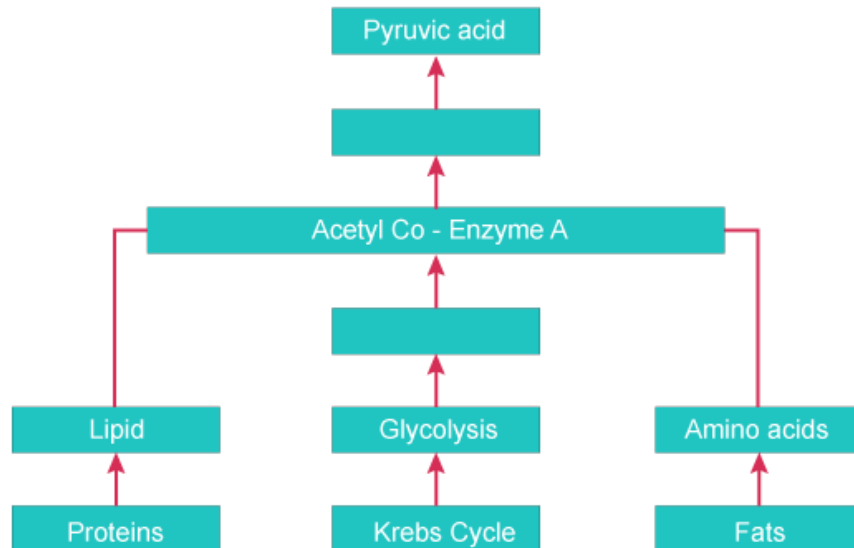

(2) Name the following:

Hormone secreted by the testis of the male reproductive system.

(3) State any two points of difference between a food chain and a food web.

(4) Give the meaning of the symbol in relation to environment conservation.



(5) I am a metamerically segmented, blood-sucking ectoparasite. I have suckers. Who am I and to which phylum do I belong?

(B) Choose the correct alternative and rewrite the statements: [5]

- (1) Which phase shows a notch in the cytoplasm in between the central region?
(a) Prophase
(b) Metaphase
(c) Anaphase
(d) Cytokinesis
- (2) Which of the following reproduces through fragmentation?
(a) Yeast
(b) *Spirogyra*
(c) *Hydra*
(d) *Rhizopus*
- (3) Which phylum includes organisms with jointed appendages?
(a) Arthropoda
(b) Annelida
(c) Cnidaria
(d) Platyhelminthes
- (4) Where is the largest hydroelectric power station located in Maharashtra?
(a) Koyna-Pofali
(b) Jayakwadi
(c) Lonavala
(d) Bhira
- (5) Which of the following addiction is the most harmful for the nervous system?
(a) Smoking
(b) Chewing tobacco
(c) Alcohol consumption
(d) Chewing gutkha

2. Solve the following: (Any 5)

[10]

- (1) Observe the pictures below. Identify the mode of reproduction shown in each of these and name an organism which reproduces by this method.

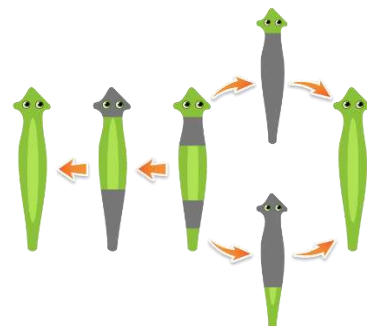

(A)

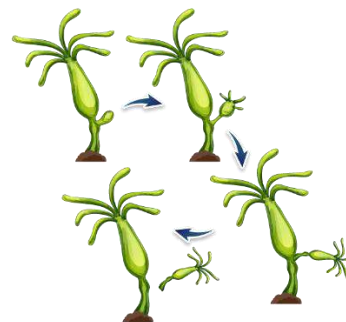

(B)

(2) Fill in the boxes with the appropriate stages in tissue culture.

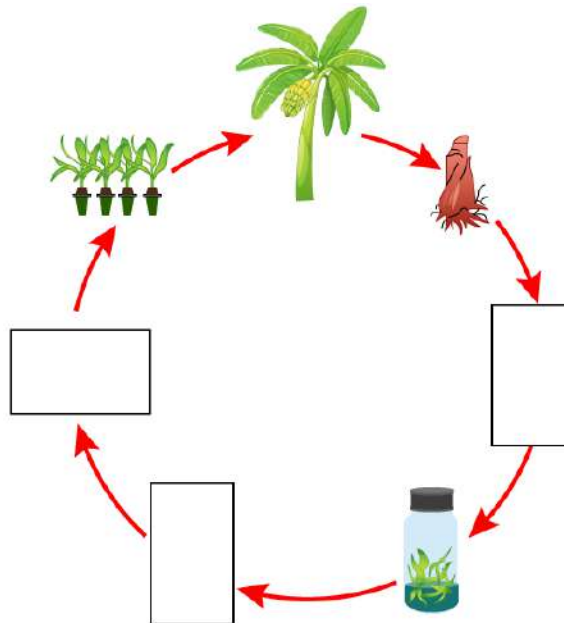

(3) What is lake tapping? What is the advantage of lake tapping?

(4) Complete the chart.

Microbes performing tasks of cleaning	Function
Pseudomonas
.....	Absorb radiations from radioactive debris
Genetically modified India mustard
.....	Absorbing uranium and arsenic

(5) What precaution and care will you take in case of fire?

(6) List the basic steps for producing milk products.

(7) What measures will you take to reduce stress?

3. Attempt the following in brief: (Any 5)

[15]

(1) Observe the following diagram and answer the questions based on your observations.

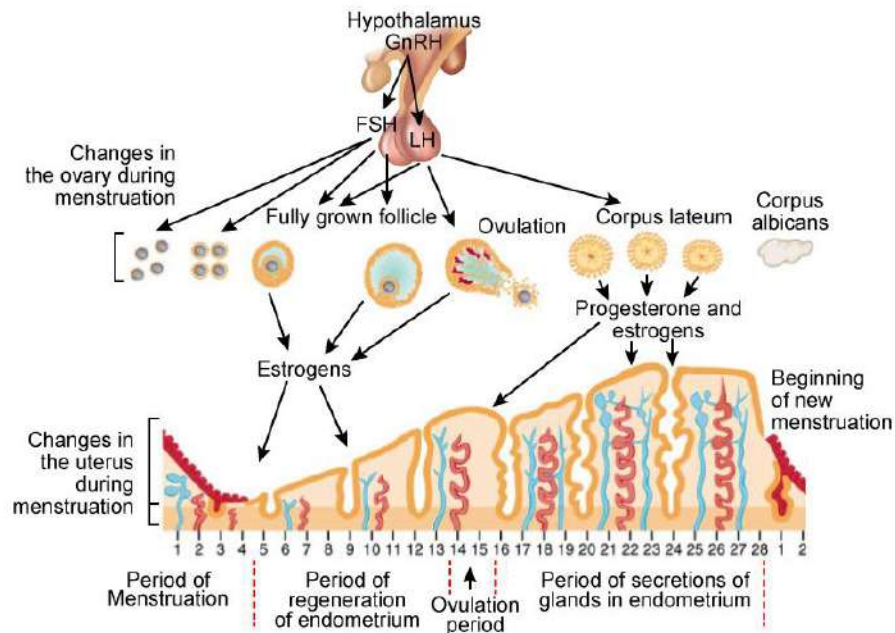

- In the menstrual cycle, which reproductive organs undergo change?
- Which period is said to be the period of regeneration of the endometrium?
- Which period is said to be the period of secretion of glands in the endometrium?

(2) Observe the diagram and answer the questions below.

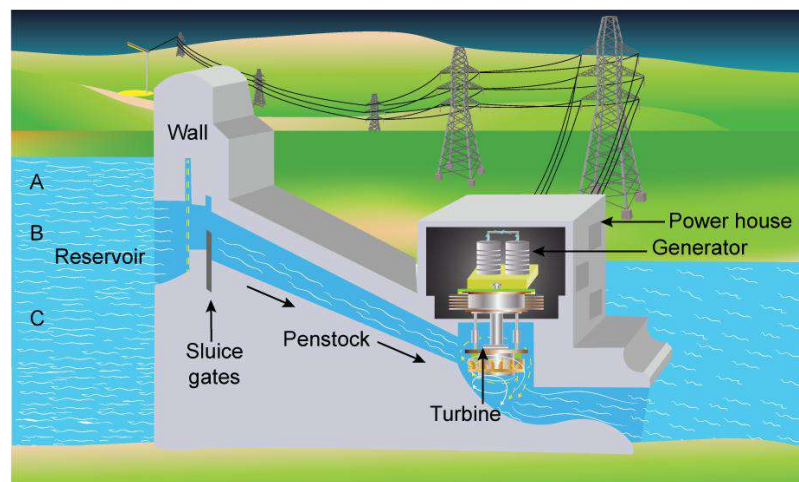

- With reference to Point B, potential energy of how much water reservoir in the dam will be converted to kinetic energy?
- What will be the effect on electricity generation if the channel taking water turbine starts at Point A?
- What will be the effect on electricity generation if the channel taking water turbine starts at Point C?

(3) Identify the organisms and mention the phylum or class to which they belong.



(A)



(B)

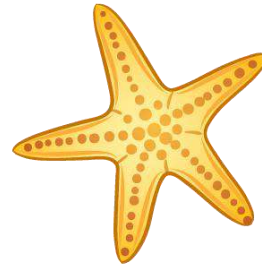

(C)

(4) What are three major classes of RNA? Mention their functions.

(5) Observe the given diagrams and answer the questions which follow.

(a) Label the given diagram.

(b) What is the function of the given system?

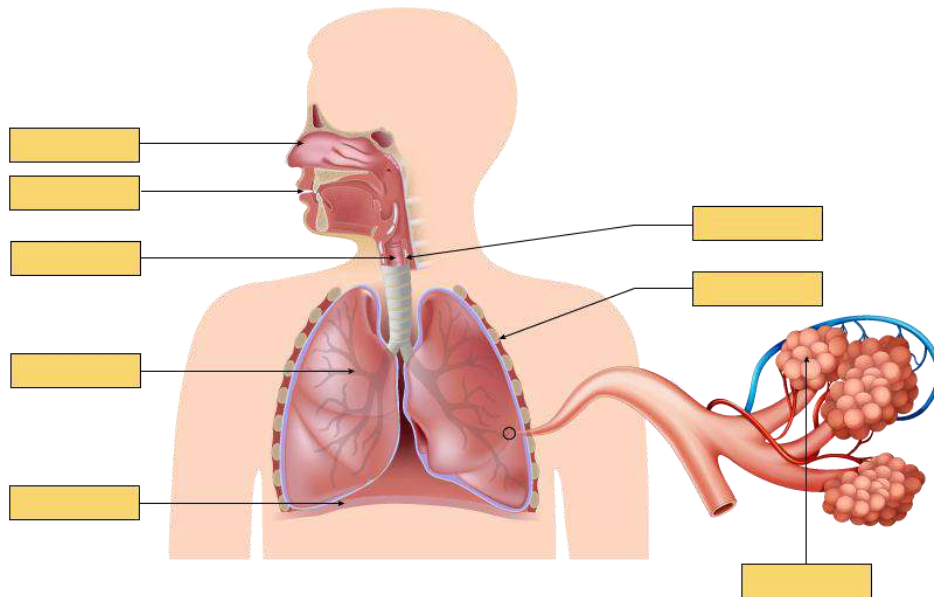

(6) One solar panel produces a potential difference of 18 volts and current of 3 A. Describe how you can obtain a potential difference of 72 volts and current of 9 A with a solar array using solar panels. You can use the sign of a battery for a solar panel.

(7) List the characteristics of pre-disaster management.

4. Attempt in detail: (Any 1)

[5]

(1) Observe the diagrams of solar cells below.

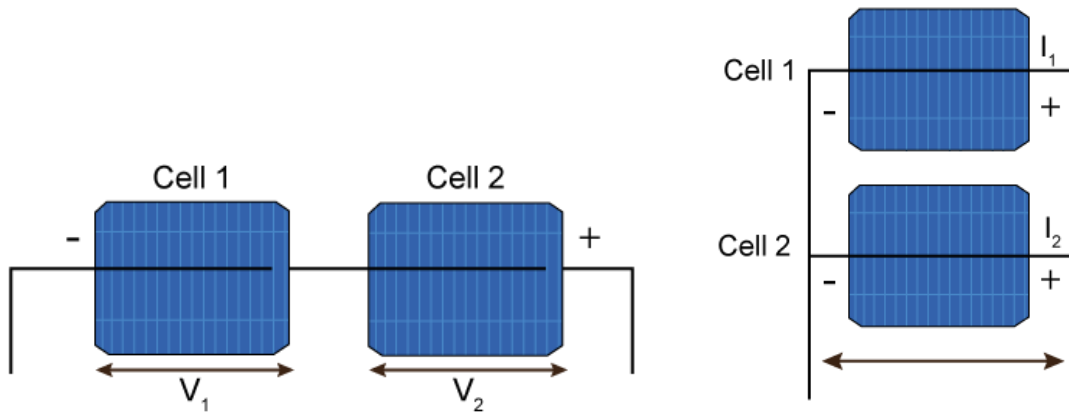

- (a) Label the solar cells with reference to potential difference and current produced by these two types of combinations.
- (b) What happens when two solar cells are connected in series?
- (c) What happens when two solar cells are connected in parallel?
- (d) What are the advantages and limitations of using solar energy?

(2) Observe the diagram given and answer the questions based on it.

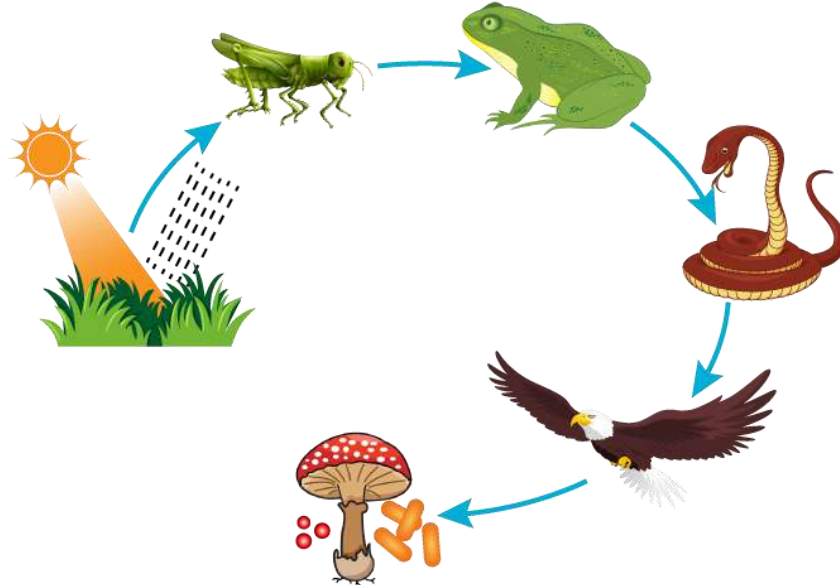

- (a) Label the food chain properly according to the trophic levels.
- (b) If the number of frogs shown in the above food chain is suddenly reduced, then what can be the different effects on the food chain?
- (c) Which components of the above food chain, if lost, will reflect upon the process of decomposition? What will be the effect of this on the ecosystem?

Maharashtra State Board
Class IX
Science and Technology Paper – II
Sample Paper 1 Solution

1. (A)
 (1)

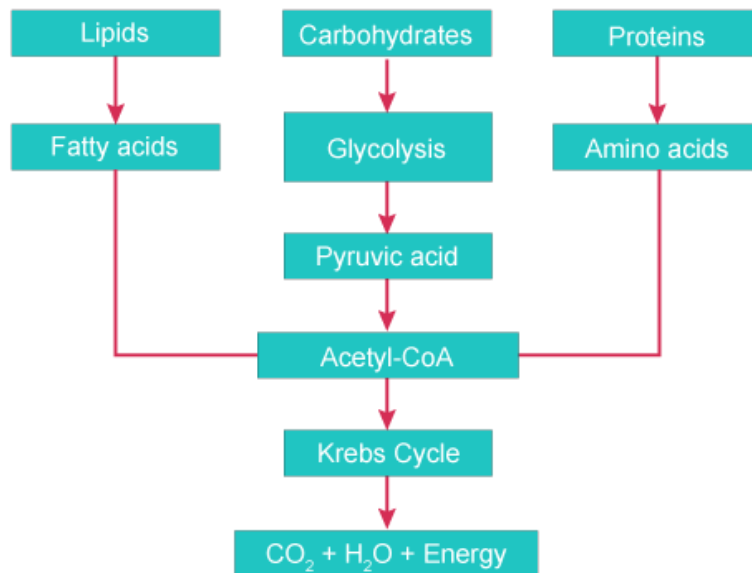

(2) Testosterone

(3) Differences between a food chain and a food web:

Food chain	Food web
It is a single straight pathway through which food energy travels in an ecosystem.	It consists of several interconnected food chains through which food energy travels in an ecosystem.
Members of a higher trophic level feed upon a single type of organism of a lower trophic level.	Members of a higher trophic level feed upon many different organisms of a lower trophic level.
Isolated food chains increase the instability of the ecosystem.	Complex food webs increase the stability of the ecosystem.

(4) The given symbol explains the message of saving or conserving water. Sustainable use of water is necessary for our future.

(5) Leech. Phylum Annelida

(B)

(1) Cytokinesis

During cytokinesis, a notch is formed at the equatorial plane of the cell which deepens gradually and thereby gives rise to two new cells.

(2) *Spirogyra*

Filaments of *Spirogyra* break into many fragments. Each fragment then begins to grow independently as a new organism.

(3) Arthropoda

Animals with jointed appendages are called arthropods.

(4) Koyna-Pofali

The largest hydroelectric power station is located in Koyna-Pofali in Maharashtra.

(5) Alcohol consumption

Efficiency of the nervous system and liver decreases due to alcoholism.

2.

(1)

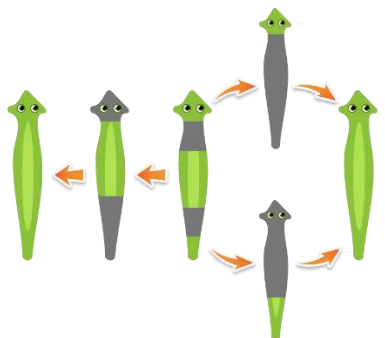
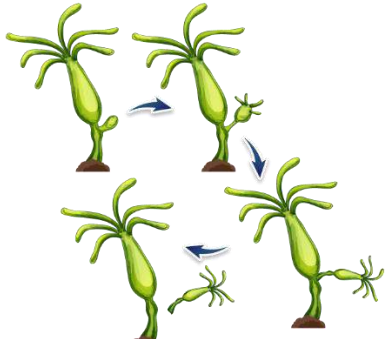
Organism	Mode of reproduction	Example
(A) 	Regeneration	<i>Planaria</i>
(B) 	Budding	<i>Hydra</i>

(2) Stages in tissue culture:

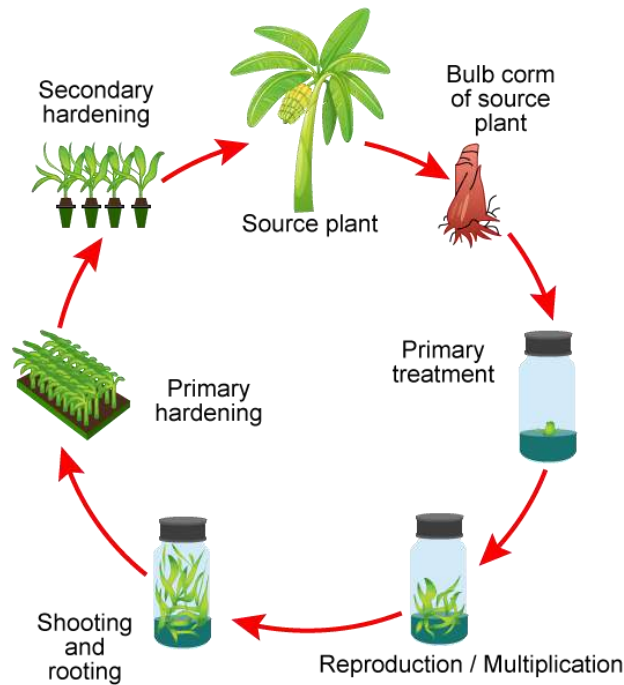

(3) A lake tap involves excavating a tunnel at the bottom of the lake. Dynamites are planted therein and blasted carefully. Water flows with greater force through the tunnel after such blasting. This increased water flow is then driven to the hydroelectric power generation plant for increased electricity production.

Advantages of lake tapping: (Any two)

- To establish waterways for hydropower
- To make drinking water available
- To make water available for irrigation purposes
- For landing of oil and gas pipes from offshore fields

(4)

Microbes performing tasks of cleaning	Function
<i>Pseudomonas</i>	Cleaning the hydrocarbon and oil pollutants from soil and water
<i>Deinococcus radiodurans</i>	Absorb radiations from radioactive debris
Genetically modified India mustard	Absorb selenium from soil
<u>Genetically modified sunflower</u>	Absorbing uranium and arsenic

(5) **Precautions in case of fire:**

- Save yourself first and then help others in rescue operations.
- Help others to extinguish the fire.
- Call the fire department for immediate action.

(6) **Basic steps for producing milk products:**

- Pasteurisation of milk initially to eradicate other harmful bacteria.
- Fermentation using Lactobacilli.
- Conversion of lactose sugar of milk to lactic acid.
- Coagulation of milk proteins by lactic acid.
- Formation of compounds with buttery flavour such as diacetyl which impart taste and flavour.

(7) **Measures taken to reduce stress:**

- Sing and listen to soft music.
- Express my feelings with my near and dear ones.

3.



(1)

- (a) In the menstrual cycle, reproductive organs such as follicles inside the ovary and the endometrium of the uterus.
- (b) The period of regeneration of the endometrium includes Day 5 to Day 13.
- (c) The period of secretion of glands in the endometrium includes Day 16 to Day 28.

(2)

- (a) When the sluice gate near Point B is opened, water starts flowing: potential energy of stored water which is allowed to pass through the sluice gate is converted to kinetic energy.
- (b) If a channel taking the water to the turbine starts at Point A, water flows with greater speed. Water acquires more speed as Point A is at a height. Thus, the kinetic energy generated because of the flowing water rotates the blades of the turbine.
- (c) As Point C is at a lesser height, water will not acquire the required speed, and thus, the blades of the turbine will not rotate efficiently. Thus, the production of electricity will be less.

(3)

	Organisms	Phylum
(A) 	Sea anemone	Cnidaria/Coelenterata
(B) 	Leech	Planaria
(C) 	Starfish	Echinodermata

(4) **Three major classes of RNA and their functions:**

- tRNA: Carries amino acid from the cytoplasm to the mRNA in ribosomes for translation
- mRNA: Carries information for protein synthesis from DNA to ribosomes
- rRNA: Component of ribosomes and provides a surface for the attachment of mRNA and tRNA

(5)

(a) **Human respiratory system**

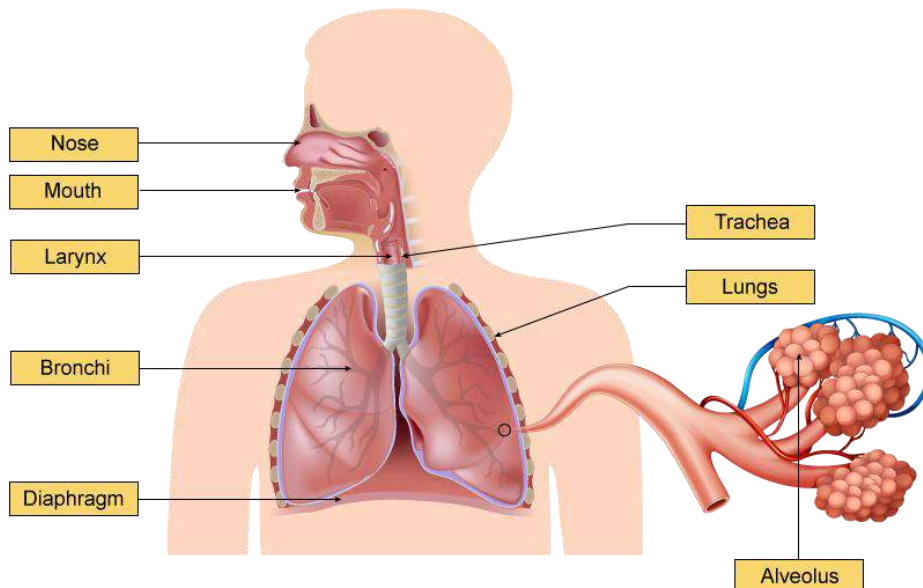

(b) The main function of the respiratory system is to transport air into the lungs and facilitate the diffusion of oxygen into the blood stream. It also receives waste in the form of carbon dioxide from the blood and exhales it out.

(6) We know that,

When solar cells are connected in series,

Potential difference $V_{\text{total}} = V_1 + V_2$

And the current $I = I_1 = I_2$

When solar cells are connected in parallel,

Total current $I = I_1 + I_2$

And potential difference $V = V_1 = V_2$

Thus, the solar cells of potential difference 18 V and current 3 A can be arranged to make a solar array to obtain potential difference 72 V and current 9 A.

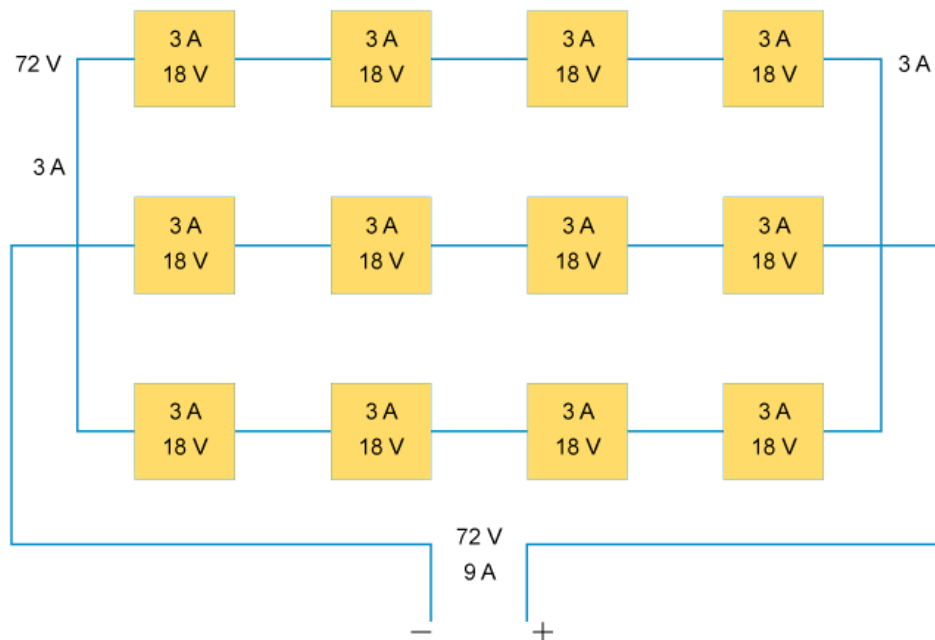

(7) Characteristics of pre-disaster management:

- Identifying the pro-disaster areas.
- Collecting information about the intensity of disaster and probable sites of a disaster through predictive intensity maps and hazard maps, respectively.
- Getting special training for disaster management.
- Increasing awareness about disaster management among the public through training programmes.

4.

(1)

(a)

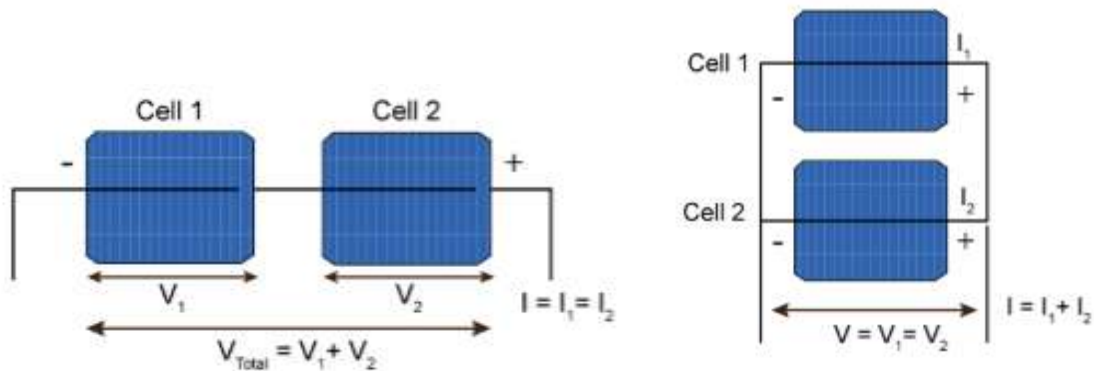

(b) When two solar cells are connected in series, the potential difference obtained by this combination is the addition of the potential difference of individual solar cells.

The current generated is equal to the current from an individual cell.

Thus, total potential difference $V_{\text{total}} = V_1 + V_2$

And the current $I = I_1 = I_2$

(c) When two solar cells are connected in parallel, the current generated from this combination is the summation of the current flowing from individual cells.

The potential difference is equal to the potential difference obtained from individual cells.

Thus, total current $I = I_1 + I_2$

And potential difference $V = V_1 = V_2$

(d) **Advantages:**

- Solar power is pollution-free and does not cause emission of greenhouse gases.
- Renewable and clean energy is available every day.
- It is used to heat water, and to supply power to homes and electric cars.

Disadvantages:

- High costs for initial installation.
- Needs a lot of space as efficiency is not 100%.
- No solar power is generated in the absence of sunlight. Thus, large battery banks are required.

(2)

(a) **Food chain**

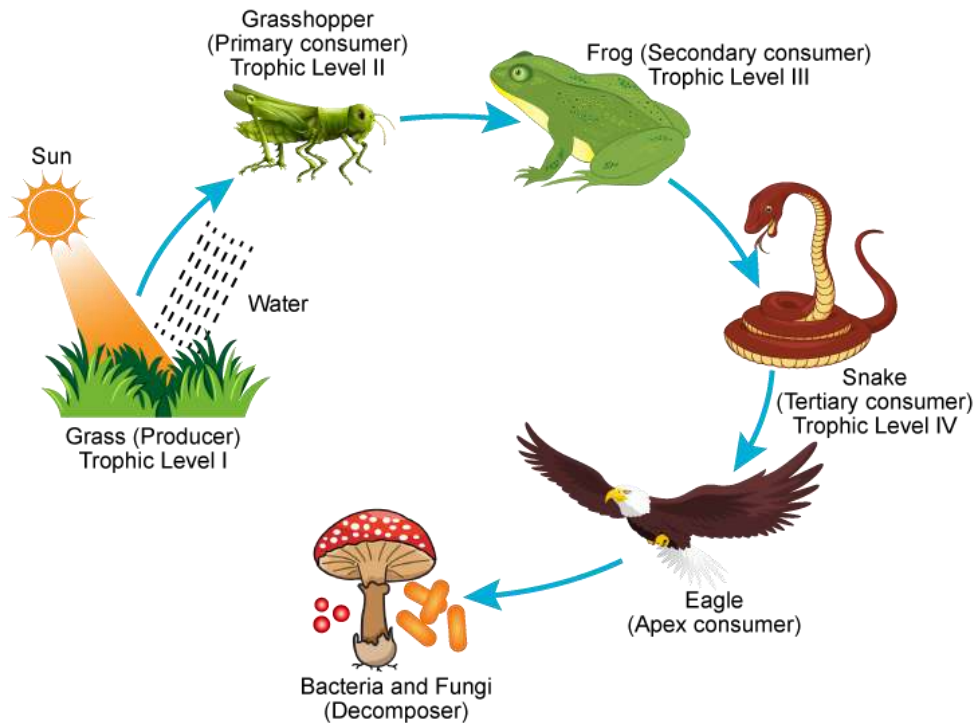

(b) If the number of frogs in the food chain is suddenly reduced, there will be a sudden rise in the grasshopper population, which are prey for frogs. Because of a sudden reduction in the frog population, the snake population which feeds on frogs will also decrease suddenly because of lack of food. There would be an imbalance of the entire ecosystem. The number of prey and predator populations will change, and thus, the food chain will come to an end.

(c) Decomposition would be affected if bacteria and fungi are lost from the food chain. This is because these organisms act as decomposers in nature. They help breakdown the elements and molecules trapped in the bodies of organisms and send them back to nature. In the absence of decomposers, these components will not be sent to nature and the cyclic flow of these elements will be disturbed. If such decomposition halts for years, the entire Earth will be covered by heaps of unwanted garbage. The entire balance of the ecosystem would be lost.